



# iCAT

## Safety & Flexibility in perfect interaction!

**iCAT** – the robot mount for the latest generation of welding robots – with central service cables guided through the 6<sup>th</sup> Axis– offering a high level of safety & flexibility.

In case of a collision of the welding torch with the work piece, a mechanical deflection of the **iCAT** of 11° is realised.

The **iCAT** takes over the “Buffer Zone” to avoid damages of the welding torch, periphery as well as of the robot. Another safety aspect is provided by the integrated crash protection of the **iCAT** which – during a “crash” – is reacting in addition to the collision software of the robot controlling and is stopping the robot immediately.

More features of the **iCAT** are the rugged and simple design, the easy installation, the extremely torsion resistant cable assembly-excursion ( $\pm 240^\circ$ ) in the 6<sup>th</sup> axle as well as the interface with the powerful air-cooled welding torch of the series ABIROB® A.

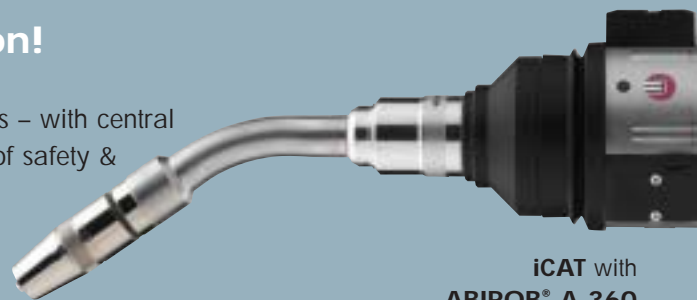

**iCAT with  
ABIROB® A 360**

Welding & cutting brought to the point.



# Robot mount "iCAT"

## Safety & Flexibility in perfect interaction!

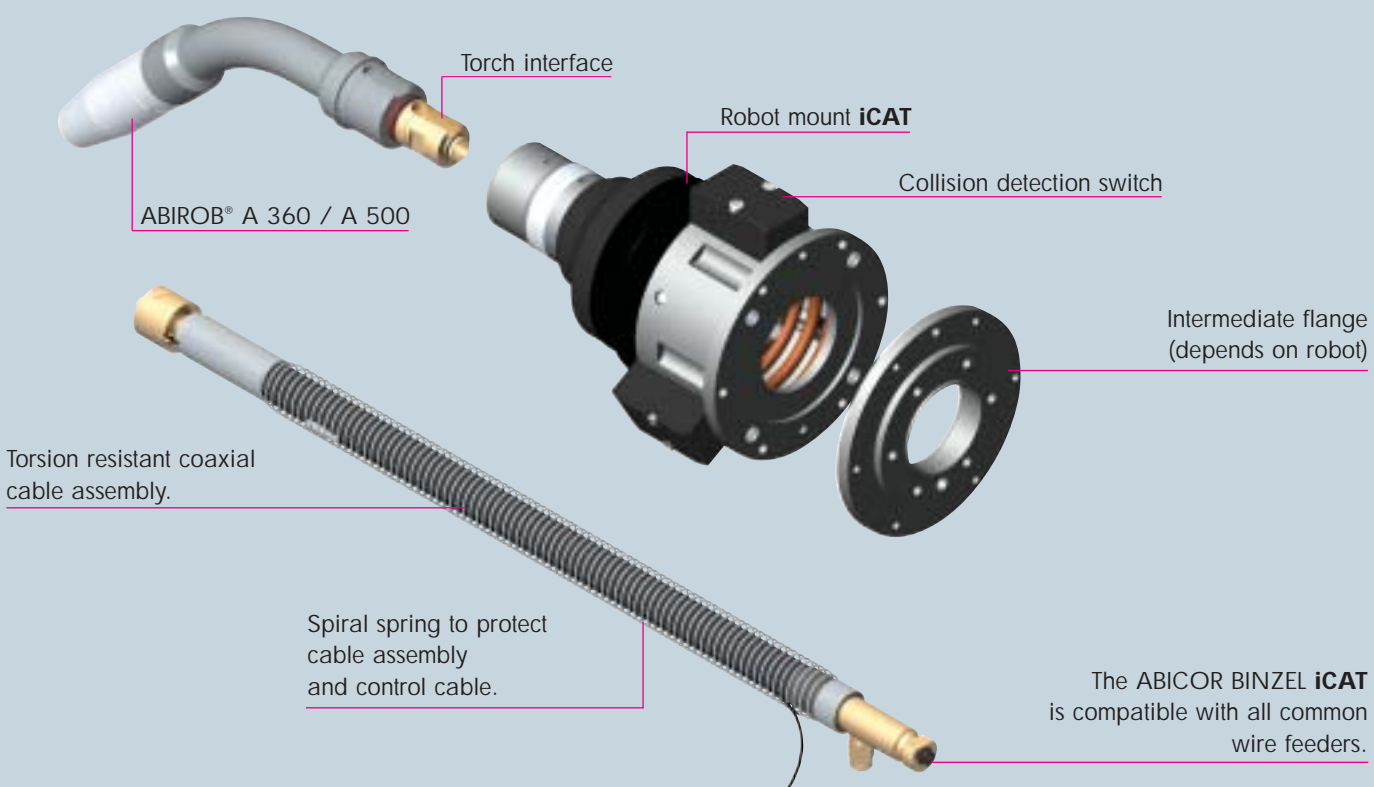

**Technical data:**

Weight incl. torch:	1.900 g
Excursion:	approx. 11°
Repeat accuracy:	≤ +/- 0.05 mm
Dimension:	max. Ø 100 mm
TCP (15 mm stick-out):	X = 372 mm

**Technical data standard torches ABIROB® A (air-cooled) according to EN 60 974-7:**

**ABIROB® A 360**

Rating:	360 A CO <sub>2</sub> 290 A Mixed gases M21 (EN 439)
Duty cycle:	100%
Wire size:	0.8-1.4 mm

**ABIROB® A 500**

Rating:	500 A CO <sub>2</sub> 400 A Mixed gases M21 (EN 439)
Duty cycle:	100%
Wire size:	0.8-1.6 mm

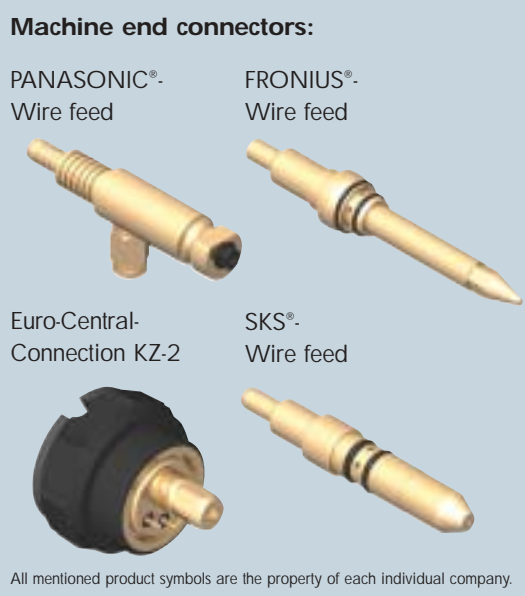

**... solution for liquid-cooled torches coming soon!**

Welding & cutting brought to the point.



Alexander Binzel Schweisstechnik GmbH & Co. KG  
 P.O. Box 10 01 53 · D-35331 Gießen  
 Phone: ++49 (0) 64 08 / 59-0  
 Fax: ++49 (0) 64 08 / 59-191  
 Internet: www.binzel-abicor.com